

12 SB 9 (12V 9Ah)

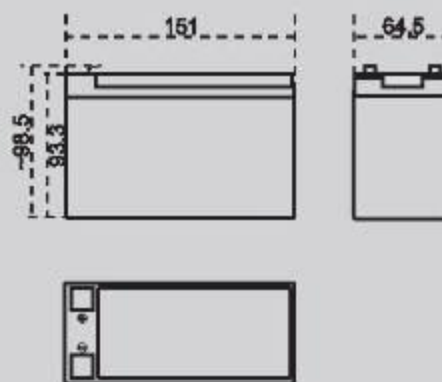

RAEMT

Outer Dimensions (mm)



Specifications

Nominal Voltage		12 V
Rated Capacity (10 Hour Rate)		9 Ah
Dimensions	Total Height	98 mm
	Height	94 mm
	Length	151 mm
	Width	65 mm
Container Material		ABS (UL94-HB/V0)
Weight Approx (±2.5%)		2.7 Kg

Terminal Type (mm)

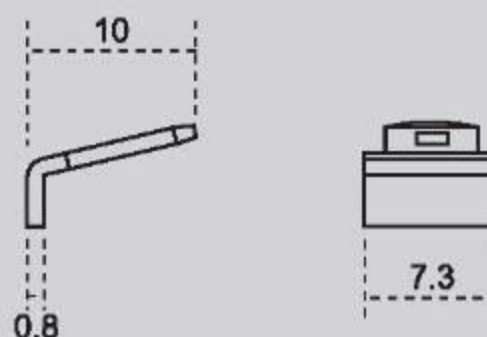

Characteristics

Capacity 25°C (77°F)	10 hour-rate 3 hour-rate 1 hour-rate	9 Ah 6.75 Ah 4.68 Ah
Internal Resistance	Full Charge Battery at 25°C (77°F)	20 m
Capacity Affected by Temperature (10 Hour Rate)	35°C 25°C 0°C -10°C	9.1 Ah 9 Ah 7.68 Ah 6.36 Ah
Self-Discharge at 25°C (77°F)	Capacity After The 3 Month of Storage Capacity After The 6 Month of Storage Capacity After The 12 Month of Storage	91 % 82 % 64 %
Charge Constant Voltage	Cycle	Voltage 2.40-2.45 / Cell
	Float	Voltage 2.23-2.25 / Cell

Discharge Curves 25°C (77°F)

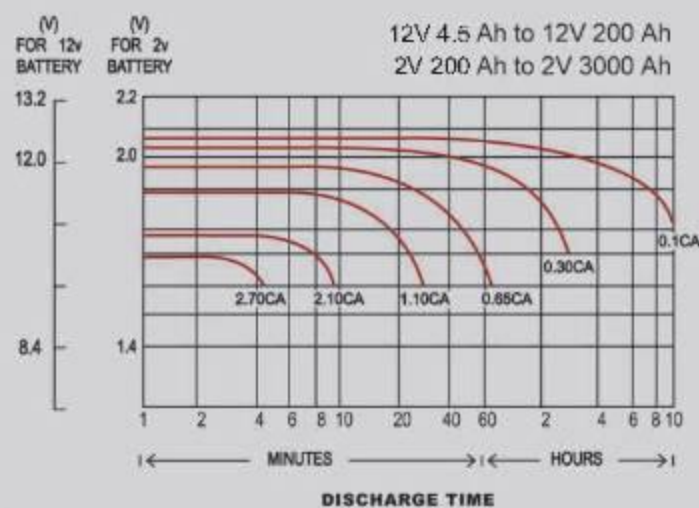

Discharge and Final Voltage Table According to IEC60896-21 Standard

Discharge time	0.25 h	1 h	3 h	5 h	8 h	10 h
Final voltage	1.60 VPC	1.60 VPC	1.70 VPC	1.73 VPC	1.75 VPC	1.80 VPC

Constant Current (A) Discharge Table at 25°C (77°F)

Amount of Current (A)	Discharge Time						
	1 h	2 h	3 h	5 h	8 h	10 h	20 h
	4.68	3.04	2.25	0.99	0.95	0.9	0.45