

# 12 SB 12 (12V 12Ah)

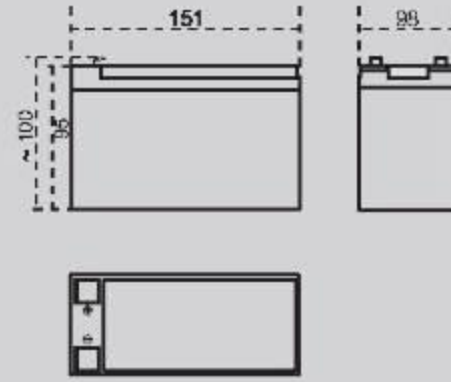

# RAEEMT

## Outer Dimensions (mm)



## Specifications

Nominal Voltage		12 V
Rated Capacity ( 10 Hour Rate )		12 Ah
Dimensions	Total Height	100 mm
	Height	95 mm
	Length	151 mm
	Width	98 mm
Container Material		ABS (UL94-HB/V0)
Weight Approx (±2.5%)		3.8 Kg

## Terminal Type (mm)

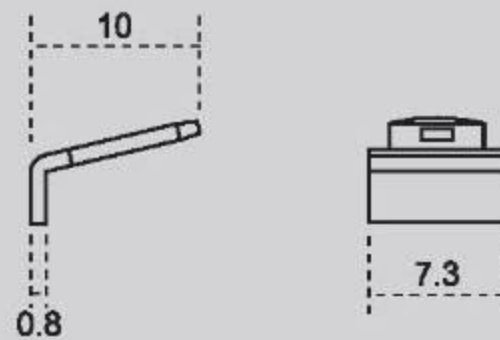

## Characteristics

Capacity 25°C (77°F)	10 hour-rate 3 hour-rate 1 hour-rate	12 Ah 8.5 Ah 6.2 Ah
Internal Resistance	Full Charge Battery at 25°C (77°F)	20 m
Capacity Affected by Temperature (10 Hour Rate)	35°C	12.16 Ah
	25°C	12 Ah
	0°C	10.25 Ah
	-10°C	8.5 Ah
Self-Discharge at 25°C (77°F)	Capacity After The 3 Month of Storage	91 %
	Capacity After The 6 Month of Storage	82 %
	Capacity After The 12 Month of Storage	64 %
Charge Constant Voltage	Cycle	Voltage 2.40-2.45 / Cell
	Float	Voltage 2.23-2.25 / Cell

## Discharge Curves 25°C (77°F)

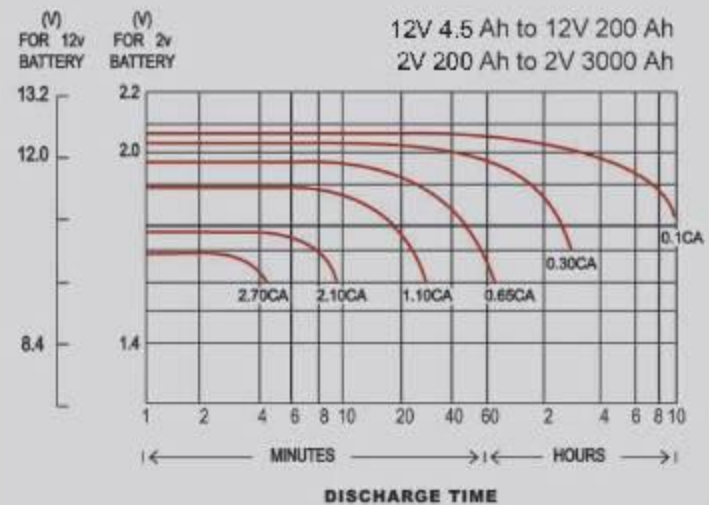

## Discharge and Final Voltage Table According to IEC60896-21 Standard

Discharge time	0.25 h	1 h	3 h	5 h	8 h	10 h
Final voltage	1.80 VPC	1.80 VPC	1.70 VPC	1.73 VPC	1.75 VPC	1.80 VPC

## Constant Current (A) Discharge Table at 25°C (77°F)

Amount of Current (A)	Discharge Time						
	1 h	2 h	3 h	5 h	8 h	10 h	20 h
	6.25	4	2.8	1.35	1.26	1.2	0.6